

MSX Track Spots

*Installation Instructions are applicable for other versions.



**WARNING – PLEASE READ ALL INSTRUCTIONS PRIOR TO INSTALLATION
READ AND FOLLOW ALL WARNINGS AND INSTRUCTIONS BEFORE INSTALLING OR MAINTAINING THIS PRODUCT.
TURN OFF POWER PRIOR TO ANY WORK ON THE SYSTEM OR PRODUCT.
DO NOT INSTALL DAMAGED PRODUCT.
AMBIENT TEMPERATURE AT LUMINAIRE LOCATION SHOULD NOT EXCEED 40°C DURING NORMAL OPERATION.**

Installing, wiring, and maintenance must be done by qualified persons or a certified electrician in accordance with all local and National Electrical Codes.

Warranty is voided in case of unauthorized modifications and/or improper use.

Save these instructions. Use as reference when service or maintenance is performed.

Refer to product label for voltage requirements and properly ground fixture in accordance with all local and national electrical codes.

If building and product supports optional dimming, connect dimming leads to dimming control system (provided by others). Refer to product label for dimming requirements. Isolate dimming wires individually if not in use.

IMPORTANT: Track spot is polarity sensitive, ensure to install V+ and V- of track adapter to MEVO track V+ and V-. Reference page 2. for details.

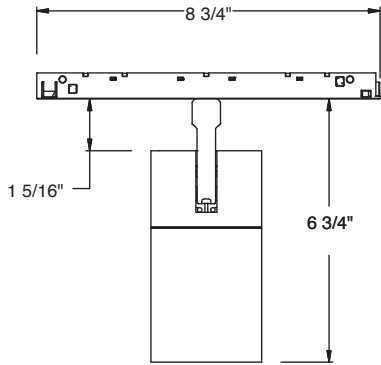

MSX25

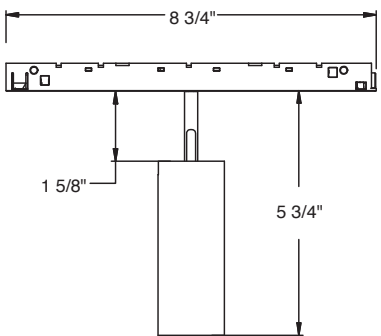

MSX10

⚠ WARNING ⚠

- To avoid possible electrical shock, before installing light fixtures, disconnect power by turning off the circuit breakers both to the outlet box and to its associated wall switch location. If you cannot lock the circuit breakers in the off position, securely fasten a prominent warning device, such as a tag, to the service panel.
- Verify that supply voltage is correct by comparing it with the luminaire label information.
- Make all electrical and ground connections in the accordance with the National Electrical Code (NEC) and any applicable local code requirements.
- Wait for fixture and driver to cool before servicing and performing maintenance.

⚠ CAUTION ⚠

- All wiring must comply with national and local electrical codes and ANSI/NFPA 70. If you are unfamiliar with wiring, consult a qualified electrician.
- PPE Personal Protective Equipment such as gloves and safety glasses should always be used when installing, maintaining or servicing.
- Risk of fire. Keep combustible material away from fixtures.

⚠ ADVERTENCIA ⚠

- Para evitar un choque eléctrico, antes de instalar luminarias, desconecte la alimentación apagando los interruptores de circuito en el panel de servicio y en las paredes. Si no es posible bloquear los interruptores en la posición de apagado, sujete una etiqueta de seguridad en el panel de servicio.
- Compruebe que la tensión de alimentación es correcta comparándola con la información en la etiqueta de la luminaria.
- Haga todas las conexiones eléctricas y puesta a tierra de acuerdo con el código eléctrico nacional (NEC) y los requisitos del código local aplicable.
- Espere hasta que la luminaria y el controlador se enfrien antes de empezar el servicio y mantenimiento.

⚠ PRECAUCION ⚠

- Todo el cableado debe cumplir con los códigos eléctricos nacionales y locales y ANSI/NFPA 70. Si no está familiarizado con el cableado, consulte a un electricista.
- Al instalar, mantener o reparar, siempre se debe utilizar equipo de protección personal como guantes y lentes de seguridad
- Riesgo de incendio. Mantenga los materiales combustibles lejos de las luminarias.

⚠ AVERTISSEMENT ⚠

- Pour éviter les chocs, avant d'installer des appareils d'éclairage, coupez l'alimentation en désactivant les disjoncteurs et l'emplacement du commutateur mural. Si vous ne pouvez pas verrouiller les disjoncteurs en position d'arrêt, fixer un avertissement sur le panneau de service.
- Vérifiez que la tension d'alimentation est correcte en le comparant avec les informations d'étiquette de luminaire.
- Effectuer tous les raccordements électriques et mise à la terre dans la conformité avec le Code électrique National (NEC) et des exigences du code local applicable.
- Laisser suffisamment de temps pour l'appareil et pilote refroidir avant d'effectuer l'entretien et la maintenance.

⚠ MIS EN GARDE ⚠

- Tout le câblage doit être effectué conformément aux codes électriques locaux et nationaux et ANSI/NFPA 70. Si vous êtes peu familier avec câblage, vous devez utiliser un électricien qualifié.
- Équipement de protection personnelle comme des gants et des lunettes de sécurité doivent être utilisé en tout temps lors de l'installation, maintenance ou entretien.
- Risque d'incendie. Garder les matières combustibles loin de luminaires.

**MEVO-TRACK
(9500-UL.../...-ST6-E)**

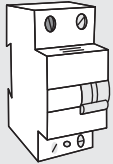

**TURN
POWER OFF**

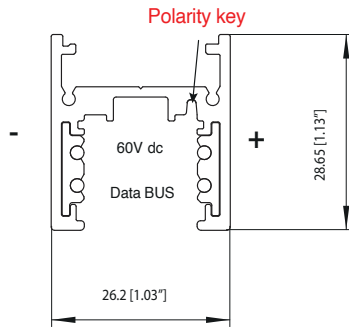
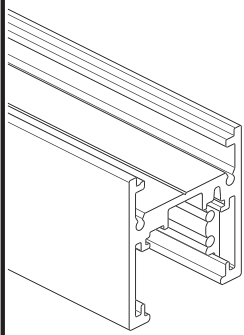

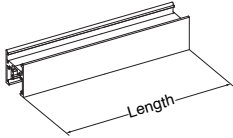
CODE	LENGTH	
MEVO-TRACK-SP-4L-4B (9500-UL4/...-ST6-E)	4'	
MEVO-TRACK-SP-8L-4B (9500-UL8/...-ST6-E)	8'	

IMPORTANT: Track spot is polarity sensitive, ensure to install V+ and V- of track adapter to MEVO track V+ and V-.

