

RENATA LONG ACOUSTIC

Canopy
SW WD E26

WEPLIGHT
COLLECTION



DESCRIPTION

- WEP Light (Wood Ecological Project) is designed, handcrafted in Argentina and assembled in the USA. A two-sided wood veneer section is fused with a malleable center panel for strength and flexibility to create a work of art in a variety of styles and sizes. A plethora of colors for interior and exterior of the shade are offered. Acoustic WEP lights are offered in multiple shapes and sizes and are NRC rated by a third-party lab for absorption efficiency. The natural recycled wood in many finish options, is complimented by a natural Argentinian lamb's wool inner shade for superior absorption. Factory assembly for most shades.
- Due to hand-crafted nature, colors vary from fixture to fixture and from photo.

HOUSING

- Sustainable, recycled, reconstructed wood veneer exterior with sound absorbing natural lamb's wool
- Factory assembled shades with some exceptions due to size

MOUNTING

- Aircraft cable suspension with black or white canopy and with 108" black or white cord, field adjustable
- Renata 80L: 9.92 lbs.
- Renata 116L: 18.7 lbs.

LISTING

- ULus listed to UL1598 (suitable for indoor use and dry locations only)
- cUL listed to CSA C22.2 #250.0
- Acoustical testing at a NVLAP Lab per ASTM C423 and ASTM E795 standards

CCT AT LIGHT LEVEL (%LF)
FOR WARM DIM LED

%LF	CCT
100%	3000
50%	2800
25%	2300
10%	1900
5%	1800

PROJECT INFORMATION

JOB NAME		TYPE	
ORDERING CODE			

ORDERING CODE

SERIES	WEP	wood shade
TYPE	REN	renata
SIZE	80L 116L	80 long pendant, 1 x light source 116 long pendant, 3 x light source
LIGHT SOURCE	LE26 ¹ LLED	E26 socket LED, 1000 lm
CCT	REN 30K 35K 3018	renata 3000K, standard white LED 3500K, standard white LED 3000K, dim to 1800K, warm dim LED Not applicable to LE26 option. Do not include in LE26 ordering code.
CRI	90 ² 95 ³	90 CRI, standard white 95 CRI, warm dim Not applicable to LE26 option. Do not include in LE26 ordering code.
MOUNTING OPTION	PBK PWH	canopy, black with black cable canopy, white with white cable
OUTER SHADE COLOR	ASH BCH BLU EBY GRN GYO OCH PGR PTB RED ROS TRC WHT WNG YLW LPT VLT	ash beech blue ebony green grey oak ocher pale green petribi red rose teracotta white wenge yellow light petrol violet
ACOUSTIC INNER SHADE COLOR	ACTN ACTB ACTG	natural black grey

ORDERING CODE

Follow the steps to specify your fixture, example:
WEP - REN - 80L - LLED - 3018 - 95 - PBK - PTB - ACTN

NOTES

1. 15W E26 socket available, use base option code LE26-15.
2. 90 CRI for standard white only.
3. 95 CRI for warm dimming only.

COLOR OPTIONS



ACOUSTIC COLOR OPTIONS

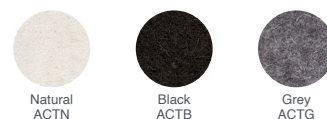

PROJECT INFORMATION

JOB NAME		TYPE	
ORDERING CODE			

LIGHT SOURCE

Light Source	LLED - Static White LED	LLED - Warm Dim LED	LE26 - E26 Socket
Performance			
LED	Cree CMT 1420	Luminus CDM-9	Lamp Dependant
Lumens	1150 lm	850 lm	
CCT	3000K or 3500K	3000K to 1800K	
SDCM	2-Step MacAdam Ellipse	3-Step MacAdam Ellipse	
CRI	>90	>95	
Lumen Maintenance	L ₉₀ > 41,500 hours	L ₇₀ > 54,000 hours	
Technical Specs			
Socket Listing	Integrated LED module ETLus Listed to UL1598 (Suitable for dry locations only) cETL Listed to CSA C22.2 #250.0	Integrated LED module ETLus Listed to UL1598 (Suitable for dry locations only) cETL Listed to CSA C22.2 #250.0	Medium E26 base socket ETLus Listed to UL1598 (Suitable for dry locations only) cETL Listed to CSA C22.2 #250.0
Mounting			
Canopy	120-277Vac, 50/60Hz input 14.3W, 14.9VA Tri-mode dimming (Triac, ELV and 0-10V)	120-277Vac, 50/60Hz input 15.6W, 16.1VA Tri-mode dimming (Triac, ELV and 0-10V)	120Vac input 100W, 100VA (max 100W lamp) Dimmable (with compatible lamp)
Warranty			
	5 year limited fixture warranty	5 year limited fixture warranty	1 year limited fixture warranty

MOUNTING OPTIONS

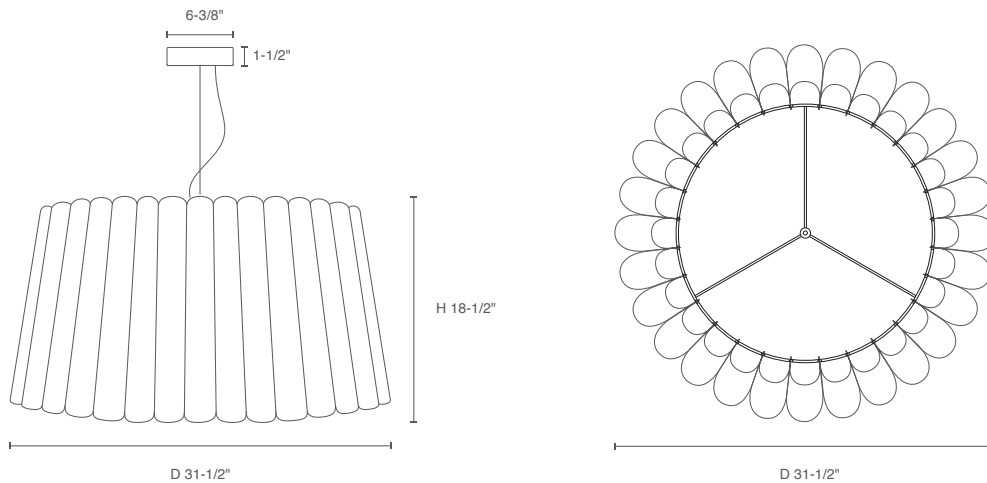

RENATA 80L ACOUSTIC

JOB NAME		TYPE	
ORDERING CODE			

MOUNTING OPTIONS

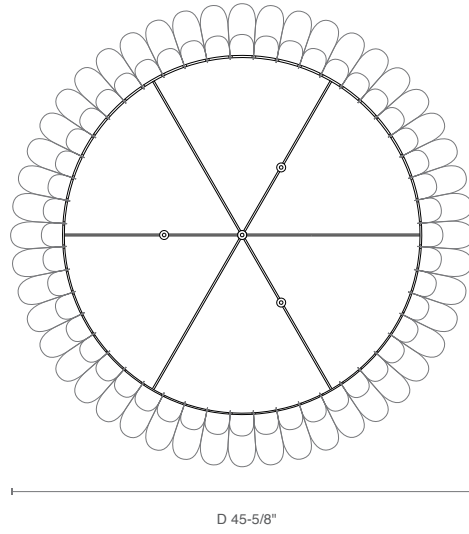
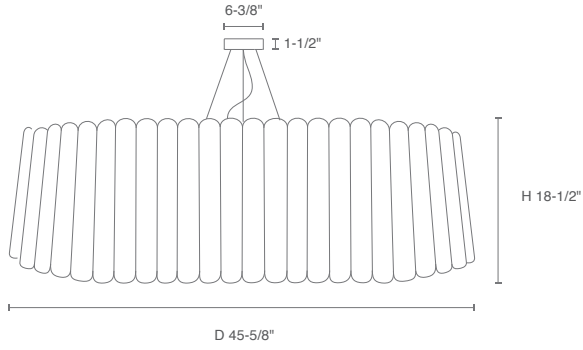

RENATA 116L ACOUSTIC

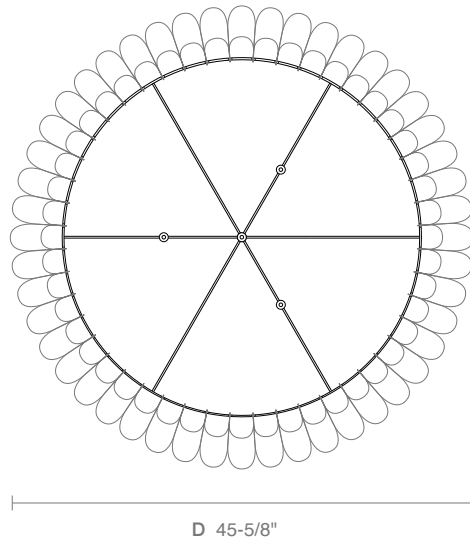
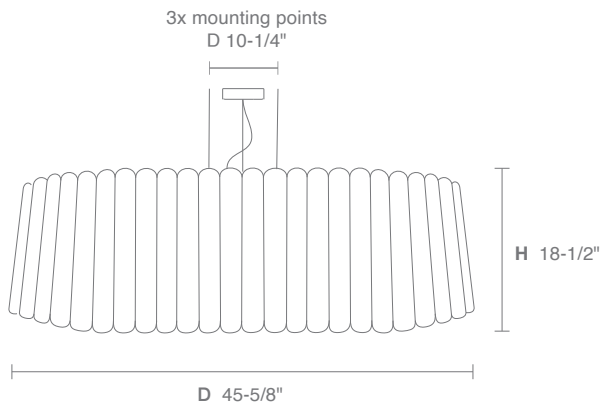

RENATA 116L LLED ACOUSTIC

PROJECT INFORMATION			
JOB NAME		TYPE	
ORDERING CODE			

SABINS PER FIXTURE

Sabins per fixture: Equivalent square feet of perfect absorption

SABINS		
CENTER FREQUENCY (HZ)	RENATA 80L	RENATA 116L
100	2.42	0.36
125	1.86	1.69
160	4.89	5.64
200	5.42	6.92
250	3.95	5.70
315	3.74	5.40
400	4.05	4.98
500	3.82	6.92
630	4.87	7.51
800	4.68	7.79
1000	5.03	8.25
1250	6.85	9.95
1600	7.18	12.17
2000	7.31	13.78
2500	9.22	15.66
3150	10.21	18.00
4000	10.87	19.77
5000	11.70	21.06
AVERAGE OF 250, 500, 1000, 2000 HZ	5.00	8.66

All test were conducted by an accredited NVLAP Lab, Riverbank Acoustical Laboratories per ASTM C423 and ASTM E795 standards.

$NRC = \frac{\text{Absorption Area (Sabins)}}{\text{Sample Area (ft}^2\text{)}}$	$\text{Sample Area (ft}^2\text{)} = \pi \times \left(\frac{D}{2}\right)^2$ (Shade)
Renata80L NRC = 0.90	Renata116L NRC = 0.80

PROJECT INFORMATION			
JOB NAME		TYPE	
ORDERING CODE			

GRAPHS

